



The PI•MTE:1300B from Princeton Instruments is an innovative, high-sensitivity imaging system designed to deliver scientific performance inside high-vacuum chambers over long operation times. The PI•MTE:1300B incorporates a back-illuminated CCD without AR coating for ultra-low-energy x-ray detection. With 20 x 20 micron pixels and 100% fill factor, this system offers a large imaging area with very high spatial resolution and dynamic range. The thermoelectrically cooled design features PCBs thermally linked to the circulating coolant to provide reliable operation inside vacuum chambers. The system's compact size and flexible tubing facilitate the positioning of the detector in limited space or on a movable arm.

**PI•MTE™**

**Applications:** soft x-ray imaging, x-ray microscopy, EUV Lithographu, x-ray plasma imaging

Features	Benefits
Exclusive Back-illuminated CCD (without AR coating)	Best response for soft x-ray
1340 x 1300 imaging array 20 x 20 μm pixels	Largest available area without AR coating for imaging
Conflat® vacuum interface	Industry-standard, high-vacuum compatibility
Unique thermal design	Efficient heat removal in high-vacuum environment
Flexible binning and readout	Increases frame rate and signal-to-noise ratio (SNR)
Compact design	For installation in limited space or on a movable arm in vacuum
Thermoelectric cooling	Minimizes dark current
Up to 2-MHz digitization	Delivers high frame rates without compromising system performance
Dual-digitizer option	Multiple-speed digitization allows complete freedom to select between "slow operation" for low noise and highest SNR or "fast operation" for rapid image acquisition
"USB 2.0 interface" configuration	Seamless, plug-and-play connection to PC notebooks and desktops Easy OEM integration
"PCI interface" configuration	Industry standard for fast data transfer over long distances
WinView and PVCAM®	Offers powerful, easy-to-use set of Windows® GUI controls Automates data acquisition, analysis and display
Linux® drivers and SITK™ plug-in for National Instruments' LabVIEW™	Extends system utility

CCD image sensor	Princeton Instruments exclusive; scientific-grade, back-illuminated, MPP device without AR coating		
CCD format	1340 x 1300 imaging pixels 20 x 20 $\mu\text{m}$ pixels 100% fill factor 26.8 x 26.0 mm imaging area (optically centered)		
	Minimum	Typical	Maximum
Linear full well	130 ke-	200 ke-	
Output amplifier	130 ke-	250 ke-	
System read noise			
@ 50-kHz digitization		3 e- rms	4 e- rms
@ 100-kHz digitization		4 e- rms	6 e- rms
@ 200-kHz digitization		6 e- rms	8 e- rms
@ 500-kHz digitization		8 e- rms	13 e- rms
@ 1-MHz digitization		10 e- rms	15 e- rms
@ 2-MHz digitization		15 e- rms	25 e- rms
Dark current @ -40°C operation		0.1 e-/p/s	0.5 e-/p/s
Deepest cooling temperature TE (chilled liquid)	-40°C	-45°C	-50°C
Vacuum Compatibility	10 <sup>-6</sup> Torr*	10 <sup>-4</sup> Torr	
Nonlinearity @ 100 kHz	2%		
Readout bits / speed	16 bits @ 50kHz to 2MHz		
Parallel shift rate	48 $\mu\text{sec}/\text{row}$		

Notes: All specifications subject to change.

\* Requires Dynamic Vacuum.

Quantum Efficiency Curve

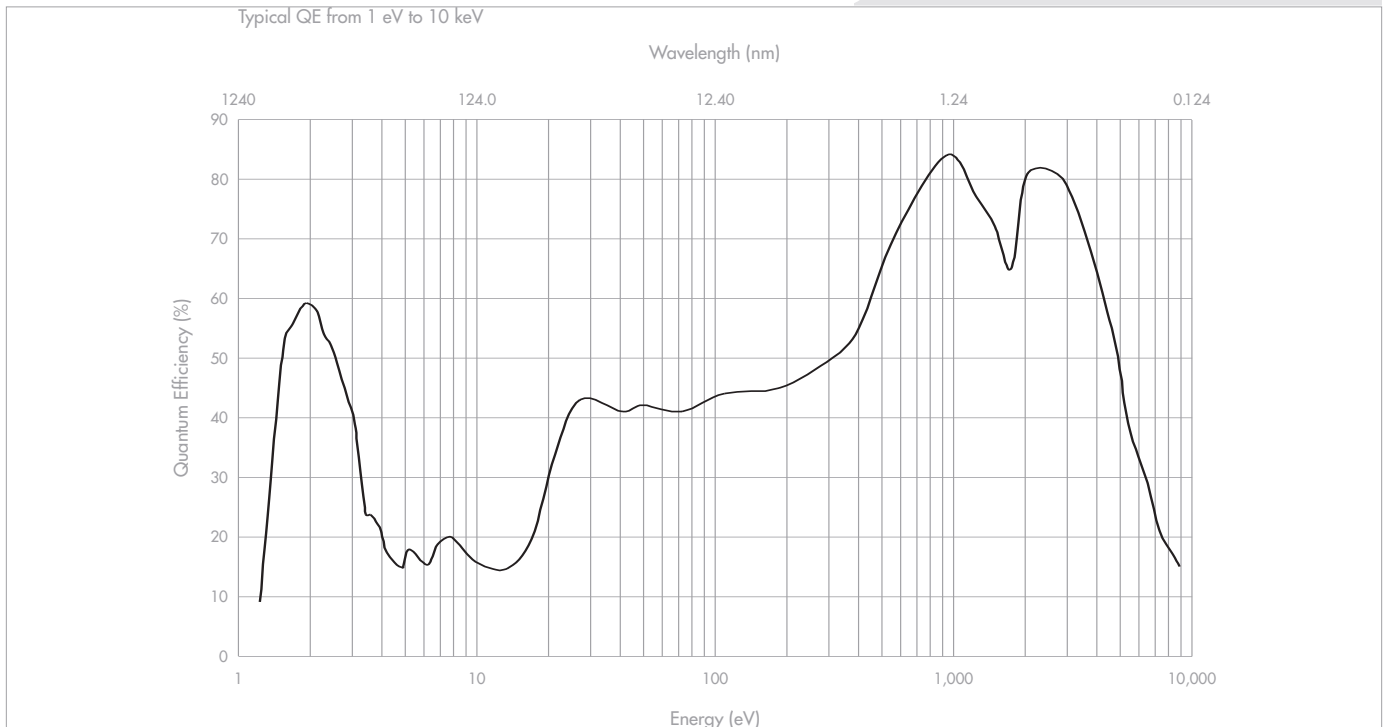

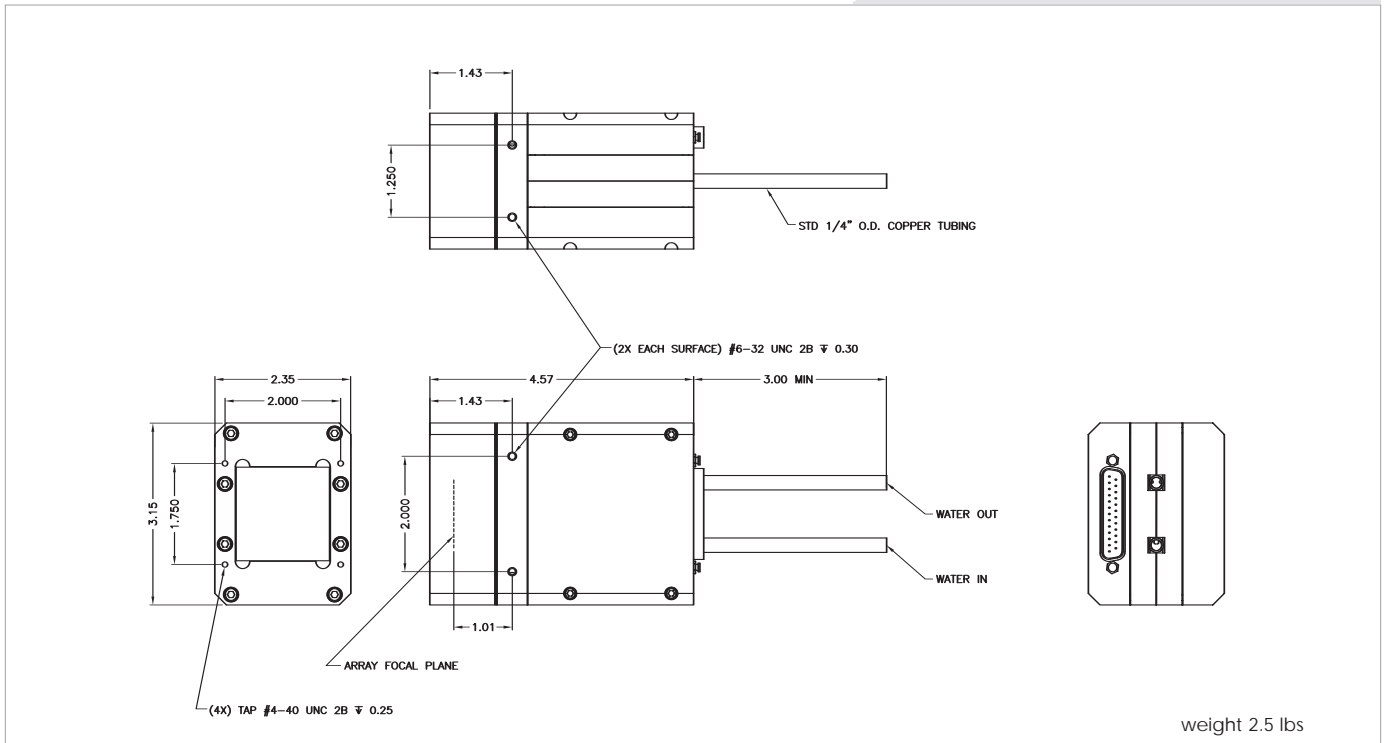

Vacuum Interface

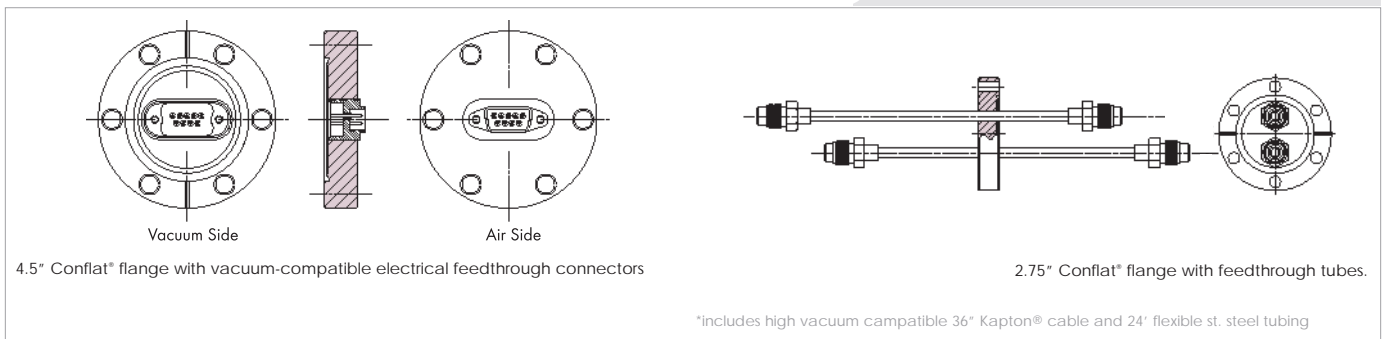

Readout Rates

Binning	@ 1 MHz	@ 100 kHz	@ 50 kHz
1 x 1	4.48 sec	42.76 sec	84.77 sec
2 x 2	1.92 sec	12.38 sec	22.52 sec
4 x 4	0.83 sec	3.75 sec	6.33 sec

**Princeton Instruments**



[www.piacton.com](http://www.piacton.com)

email: [moreinfo@piacton.com](mailto:moreinfo@piacton.com)

USA +1.609.587.9797 | Benelux +31 (347) 324989

France +33 (1) 60.86.03.65 | Germany +49 (0) 89.660.779.3

Japan +81.3.5639.2741 | UK +44 (0) 28.383101.71